

Instruction Manual



Fork Assembly

Step 1

Quantity 6 (3 per Fork)

LEFT HAND FRAME ASSEMBLY			
ITEM #	QTY	PART NUMBER	DESCRIPTION
1	1	F15350	40" FORK TOP
2	1	F15352	40" FORK BOTTOM
3	4	P15202	3/8-16 X 1.00 CARRIAGE BOLT
4	4	P15207	3/8-16 SERRATED FLANGE LOCKNUT

1) Hold Fork Bottom and Fork Top vertically and install:

- A. 3/8-16 x 1.00" Carriage Bolts (item #3)
- B. 3/8-16 Flange Locknuts (item # 4)

2) Do not fully tighten any bolts / nuts in this assembly at this time. After the sub-assemblies are complete and assembled into the main assembly, you'll tighten all of bolts / nuts.

Instruction Manual



Fork Assembly Step 1

Quantity 6 (3 per Fork)

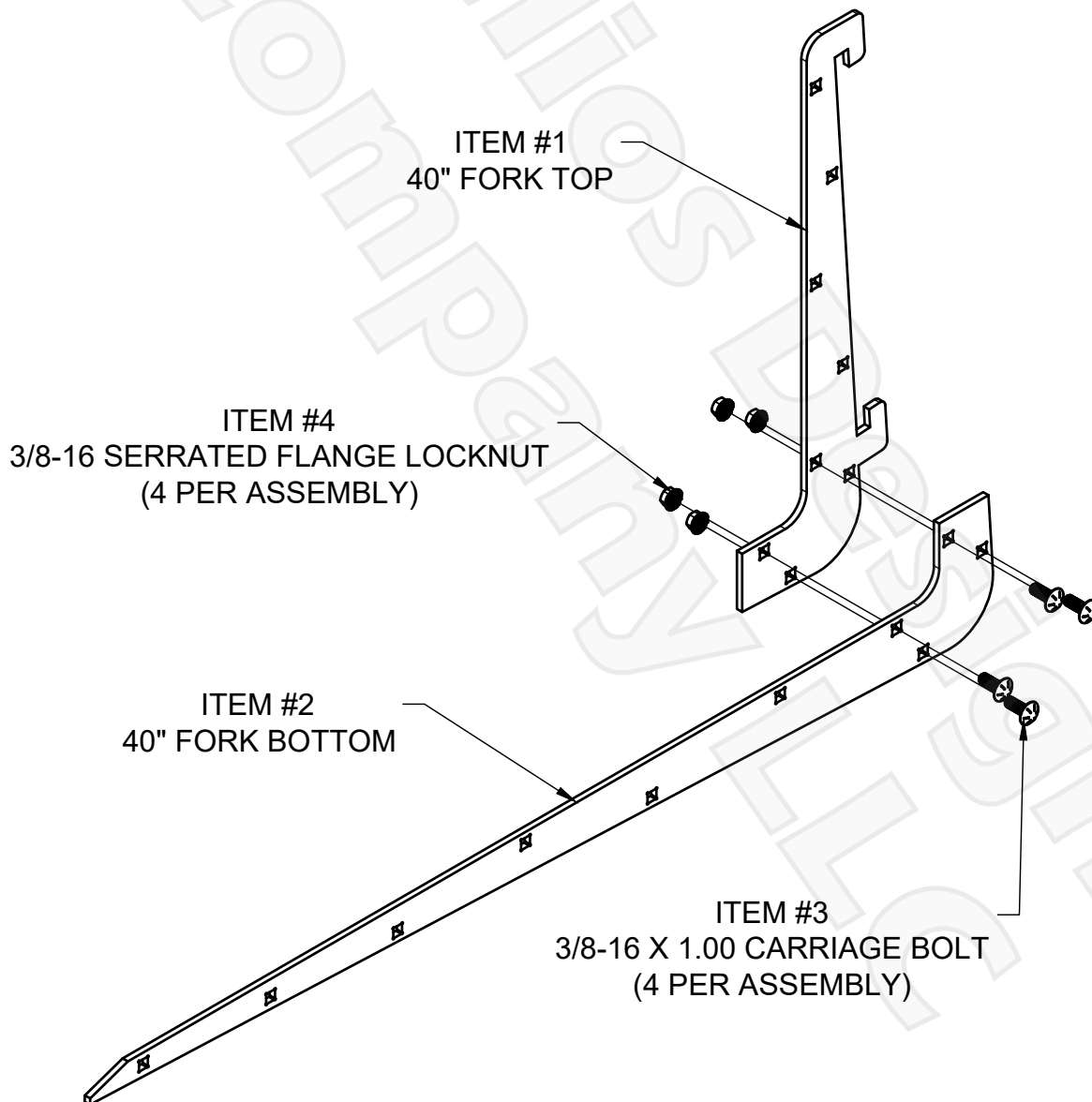

Instruction Manual



Fork Assembly

Step 2

Quantity 2

LEFT HAND FRAME ASSEMBLY			
ITEM #	QTY	PART NUMBER	DESCRIPTION
1	3	N/A	40" FORK TOP & BOTTOM SUB ASSEMBLY
2	20	F15351	.75 OD X 1.625" SPACER TUBE
3	10	P15202	3/8-16 X 4.50" CARRIAGE BOLT
4	10	P15207	3/8-16 SERRATED FLANGE LOCKNUT

1) Hold Fork sub-assemblies vertically and install:

- A. 3/8-16 x 4.50" Carriage Bolts (item #3)
- B. .75 OD x 1.625" Spacer Tubes (Item #2)
- C. 3/8-16 Flange Locknuts (item # 4)

2) After all 3/8-16 X 4.50" bolts, spacers and nuts have been installed, torque them to 25 ft. lbs.

Instruction Manual



Fork Assembly Step 2

Quantity 2

